

Vinyl Railing Acrylic Panel Installation Instructions

FAIRWAY RAILING™

BY **Envision**
OUTDOOR LIVING PRODUCTS

I It is the responsibility of the installer to meet or exceed all code and safety requirements, and to obtain all required building permits. These instructions are only a guide and may not address every circumstance. The deck and railing installer should determine and implement appropriate installation techniques for each situation.

FAIRWAY® shall not be held liable for improper or unsafe installations.

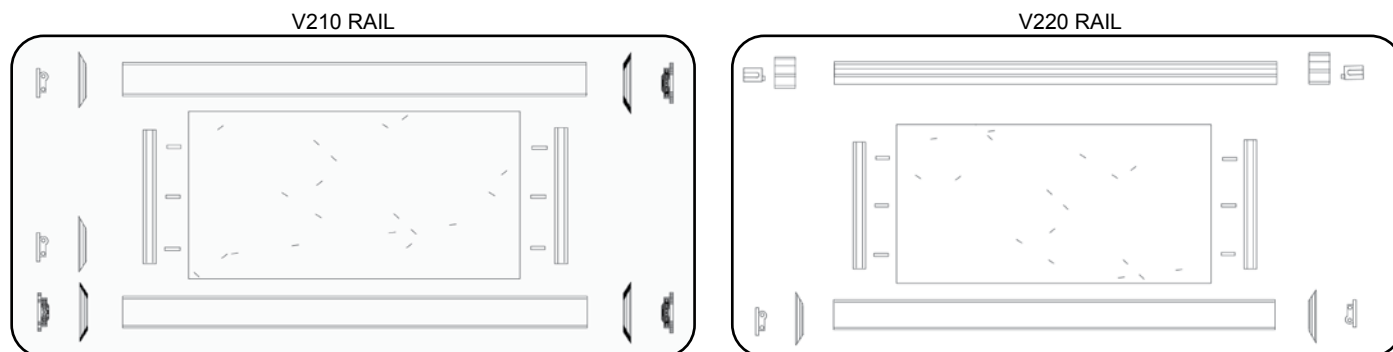

V210 Kit Includes:

- 2 ea. - V210 Vinyl Rail (Top & Bottom)
- 2 ea. - V210 Aluminum "H" Channel
- 4 ea. - V210 Level Mounting Bracket
- 2 ea. - Slotted Composite Trim Stiles
- 6 ea. - 1/8" x 3/4" Rolled Pins (Inserted in Acrylic Glass Panel)
- 6 ea. - 1/4" Neoprene Pads (Applied to Aluminum Channel)
- 1 ea. - 1/4" Acrylic Panel
- 1 ea. - Pack S.S. Mounting Screws

V220 Kit Includes:

- 1 ea. - V220 Top Rail
- 1 ea. - V210 Vinyl Rail (Bottom Rail)
- 1 ea. - V220 Aluminum Insert
- 1 ea. - V210 Aluminum "H" Channel
- 2 ea. - V220 Level Mounting Brackets
- 2 ea. - V210 Level Mounting Bracket
- 2 ea. - Slotted Composite Trim Stiles

- 6 ea. - 1/8" x 3/4" Rolled Pins (Inserted in Acrylic Panel)
- 6 ea. - 1/4" Neoprene Pads (Applied to Aluminum Channel)
- 1 ea. - 1/4" Acrylic Panel
- 1 ea. - Pack S.S. Mounting Screws

Step 1 Safety Precautions

Check all local building codes for design load requirements for railing applications. Fairway Railing is manufactured in requirements of ASTM F964-02 and is approved to meet Boca Building Code Section 61 615.8, IBC Section 160.7.7.1 and IRC Section R316, requirements pertaining to railing. Always use safety equipment when installing our maintenance-free rail system.

Step 2 Prepare Mounting Surface

Install and prepare all mounting surfaces and posts to which your new maintenance-free railing will be installed. We suggest covering wood posts with our matching-color vinyl post sleeves or wraps. Finish with one of our many styles of post caps and base trim rings.

Step 3 Mount Bottom Brackets

Determine level placement of bottom rail. This should be no greater than 4" and no less than 2 1/2" for 36" high rail. No greater than 2" for 42" high rail (below 2 1/2" use a low profile base trim ring.) Make a pencil mark where rail will be mounted. Measure up 3/8" above previous mark, square and center bottom of black bracket. Mark and pre-drill four 5/32" holes in corners of black mounting bracket. Screw bracket into place with four (4) #12 x 1 1/4" pan head screws.

Step 4 Mount Top Brackets

After bottom mounting bracket is in place, measure from bottom of bracket up (36" height: V210 railing 31 3/4" - V220 railing 31 1/4" or 42" height: V210 railing 41" - V220 railing 37 1/2") and mark with a pencil. This will be mounting mark for the bottom of the top bracket. Square and center top black mounting bracket and pre-drill four (4) 5/32" holes. Screw into place (on V210 railing use four (4) #12 x 1 1/4" - V220 railing install four (4) #10 x 2" S.S. pan head screws).

Step 5 Cut Rail to Length

Measure distance from inside black brackets for bottom rail. Remove top and bottom rail from acrylic panel by pulling rail off of acrylic panel. Remove aluminum insert from vinyl and measure the distance you need. Measure from one end (left or right) and mark. Peel off and align two (2) of the 1/4" x 1" x 2" neoprene pads for acrylic panel to rest on. Make sure pads are equal distance from each end (4 1/2" from end of rail). Install middle pad in the center of the rail. Cut the aluminum insert with a hack saw or power saw. Insert the aluminum back into the vinyl rail and trim vinyl rail to the length of the aluminum insert. Repeat this step with the top rail.

Step 6 Cutting Acrylic Panel

Once top and bottom rails are cut, measure the distance from inside post to inside post and deduct 7 1/2". This will be the width of the acrylic panel. Make sure protective covering is still on acrylic panel before cutting. From one end (left or right) lay panel on a flat solid surface, mark and cut with a fine tooth blade. After cutting is complete, you may use a file to clean the cut edge of the acrylic panel. After acrylic panel is cut to length, remove protective covering. You will need to drill and reinstall three 1/8" x 3/4" pins. On cut end, measure 2" from top and bottom of acrylic panel. Now measure over (from cut edge) 13/16" and mark. This will be the center mark for 1/8" hole. Drill an 1/8" hole and install the 1/8" pins. For the middle pin, center between top and bottom pins and repeat drilling process.

Step 7 Mounting Rail to Bracket

With top and bottom black brackets installed on mounting surface and top and bottom rails cut to length, you are ready to install railing to black mounting brackets. Set acrylic panel in slot of bottom rail, making sure you have even spacing on both ends of rail. Slide balusters over the ends of acrylic panel with 1/8" pins seated inside of baluster. You should have equal distance on both ends from edge of baluster to end of rail. Install top rail same as bottom rail. With even spacing on both ends, insert 1/4" vinyl gasket in 1/4" slot on both top and bottom rails. Using a rope or nylon strap, wrap around rail section and secure. Slide mounting bracket trim ring covers on ends of railing. Measure the distance from bottom rail to finished deck surface and cut (2) two blocks. With blocks in place, set rail section into brackets. Using #10 x 1" self tapping screw, install one (1) screw per side of mounting bracket (8 screws per section). Slide trim ring over black mounting bracket and snap into place.

Step 8 Cleanup

Your job is now complete. If your railing has any loose dirt on it from installation, simply hose it off or wipe with a soft cloth.

On **Vinyl Railing**, remove any stubborn dirt or stains using Fairway Cleaner or "0000" steel wool.

NOTE: Please take caution when cleaning the acrylic panel. Some household cleaners contain ingredients that are harmful to the acrylic panel. We recommend using a solution of warm water and liquid detergent with a soft cloth for cleaning.

Vinyl Railing Acrylic Panel Trim Stile Insert

Installation Guide

FIELD MODIFICATION OF ACRYLIC INFILL PANEL

- 1 • Deduct 7-1/2" from final rail length (this will allow 3-1/2" space between the posts and the Trim Stile on both ends).
- 2 • Remove Vinyl Sleeve. Remove 3 each #10 x 3/4" screws from Trim Stile insert on **ONLY ONE SIDE** of the Infill Panel. Remove Trim Stile Insert.
- 3 • Place Acrylic Infill Panel on a flat non-abrasive surface. Using the measurement from Step 1, mark the Infill Panel to required length - **ALL waste is removed from the side with Trim Stile removed.**
- 4 • Cut Infill Panel on your mark. Using a straight edge, cut panel with a fine tooth blade (see blade manufacturer's specs).
- 5 • Lay the waste Infill Panel atop the new Infill Panel end and pre-drill Infill Panel using the waste piece screw holes as your guide.
- 6 • Reinstall Trim Stile Insert, 3 screws and Vinyl Sleeve.



FAIRWAY RAILING™

BY **Envision**
OUTDOOR LIVING PRODUCTS

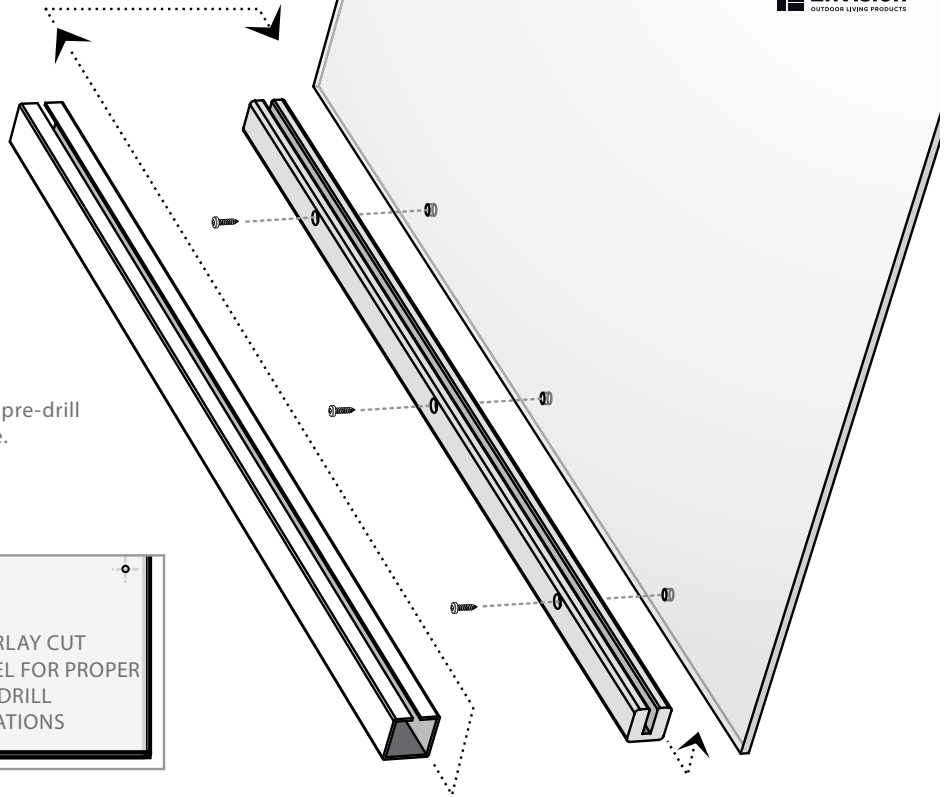

ALWAYS: Review all local building codes. Wear proper safety equipment.

909952

Vinyl Railing Acrylic Panel Trim Stile Insert

Installation Guide

FIELD MODIFICATION OF ACRYLIC INFILL PANEL

- 1 • Deduct 7-1/2" from final rail length (this will allow 3-1/2" space between the posts and the Trim Stile on both ends).
- 2 • Remove Vinyl Sleeve. Remove 3 each #10 x 3/4" screws from Trim Stile insert on **ONLY ONE SIDE** of the Infill Panel. Remove Trim Stile Insert.
- 3 • Place Acrylic Infill Panel on a flat non-abrasive surface. Using the measurement from Step 1, mark the Infill Panel to required length - **ALL waste is removed from the side with Trim Stile removed.**
- 4 • Cut Infill Panel on your mark. Using a straight edge, cut panel with a fine tooth blade (see blade manufacturer's specs).
- 5 • Lay the waste Infill Panel atop the new Infill Panel end and pre-drill Infill Panel using the waste piece screw holes as your guide.
- 6 • Reinstall Trim Stile Insert, 3 screws and Vinyl Sleeve.

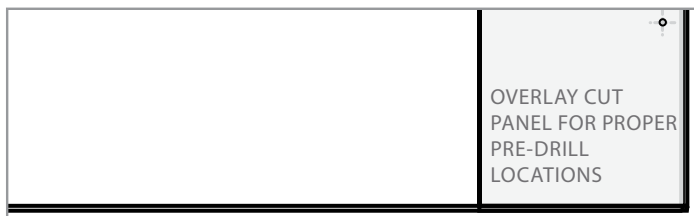

FAIRWAY RAILING™

BY **Envision**
OUTDOOR LIVING PRODUCTS

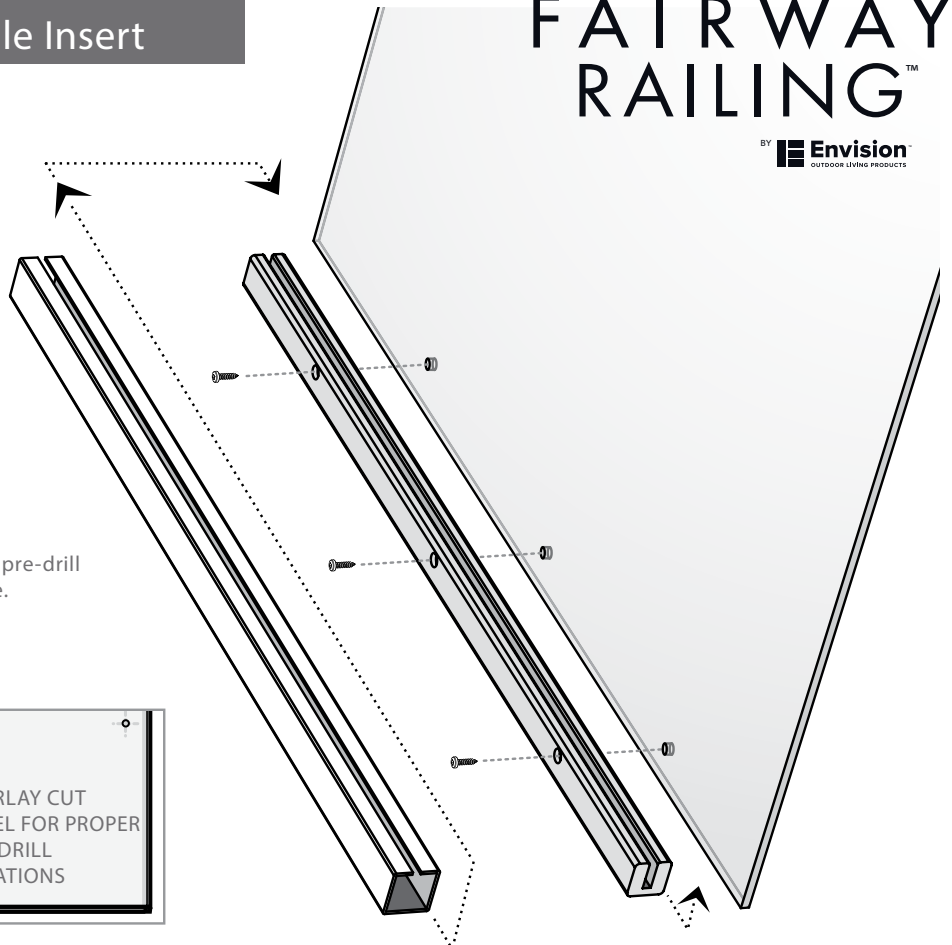

ALWAYS: Review all local building codes. Wear proper safety equipment.

909952