

Issue Date: 09-27-2020
Renewal Date: 09-30-2021

DIVISION: 06 00 00 – WOOD, PLASTICS AND COMPOSITES
Section: 06 63 00 – Plastic Railings

REPORT HOLDER:

Fairway Architectural Railing Solutions
53 Eby Chiques Road
P.O. Box 37
Mount Joy, PA 17552

REPORT SUBJECT:

Fairway V100 Series Vinyl Railing System

1.0 SCOPE OF EVALUATION

1.1 This Research Report addresses compliance with the following Codes:

- 2018 *International Building Code*® (IBC)
- 2018 *International Residential Code*® (IRC)
- 2020 *Florida Building Code* (FBC) excluding High Velocity Hurricane Zone (see Section 9.0)

NOTE: This report references 2018 Code sections with [2015 and FBC] Code sections shown in brackets where they differ.

1.2 The *Fairway V100 Series* vinyl railing systems have been evaluated for the following properties:

- Structural Performance
- Durability
- Surface Burning

1.3 The *Fairway V100 Series* vinyl railing systems have been evaluated for the following uses:

- The *Fairway V100 Series* vinyl railing systems are guards (aka. guardrails) under the definitions of the referenced codes and are intended for use on elevated walking areas in buildings and walkways, as required by the referenced codes.
- Guard assemblies are provided as level guards for level walking areas such as decks, balconies and porches, and sloped guards for open sides of stairways.

- Guard assemblies recognized in this report may be used in One- and Two-Family Dwellings regulated by the IRC and all construction types regulated by the IBC in accordance with IBC Section 705.2.2 and 705.2.3.1 [1406.3], Exception 2 and 3. Guards less than 42 inches high are limited to use in One- and Two-Family Dwellings (IRC). See Table 1 for additional restrictions based upon Use and Occupancy Classification

2.0 STATEMENT OF COMPLIANCE

The *Fairway V100 Series* vinyl railing systems comply with the Codes listed in Section 1.1, for the properties stated in Section 1.2 and uses stated in Section 1.3, when installed as described in this report, including the Conditions of Use stated in Section 6.

3.0 DESCRIPTION

3.1 The *Fairway V100 Series* vinyl railing systems are an assemblage of co-extruded and molded components, with aluminum reinforcements and mounting brackets. See Figure 1.

3.1.1 Top rails are nominally 1-3/4 inches high by 3 inches wide with 0.065-inch nominal wall thickness, “T” shaped extruded PVC rail profile, reinforced with an aluminum “T” shaped insert.

3.1.2 Bottom rails are nominally 2-1/4 inches high by 1-3/4 inches wide with 0.065-inch nominal wall thickness, rectangular extruded PVC rail profile, reinforced with an aluminum “H” shaped insert.

3.1.3 Infill are provided in 1-3/8" square PVC balusters or 3/4" dia. aluminum balusters. Rails are routed to the shape of the infill profile to receive the infill.

3.1.4 Top and bottom rails are connected to sleeved conventional wood posts using aluminum brackets, as defined in Table 2.



4.0 PERFORMANCE CHARACTERISTICS

4.1 The *Fairway V100 Series* vinyl railing systems described in this report has demonstrated the capacity to resist the design loads specified in Chapter 16 of the IBC, as well as Section R301 of the IRC when tested in accordance with ICC-ES AC174.

4.2 Structural performance has been demonstrated for a temperature range from -20°F to 125°F.

4.3 Materials used are deemed equivalent to preservative treated or naturally durable wood for resistance to weathering effects, decay, and attack from termites.

4.4 Materials used in the railing assemblies have a flame spread index not exceeding 200 when tested in accordance with ASTM E84.

5.0 INSTALLATION

5.1 The *Fairway V100 Series* vinyl railing systems must be installed in accordance with the manufacturer's published installation instructions, the applicable Code, and this Research Report. A copy of the manufacturer's instructions must be available on the jobsite during installation.

5.2 Railing assemblies consist of top and bottom rails with pre-routed holes to receive infill. Aluminum railing reinforcements are inserted in the top and bottom rails during assembly as specified for the type and length of railing (see Table 1). Aluminum insert lengths must be the same length as the vinyl railings to assure bracket screws penetrate the aluminum inserts.

5.3 Railings are secured with aluminum brackets and stainless-steel screws to structural wood support which, may include a PVC sleeved 4x4. The wood in the supporting structure shall have a specific gravity of 0.50 or greater (Southern Yellow Pine or better) and a minimum thickness to allow full penetration of the bracket mounting screws. Rail attachment shall be in accordance with Table 2.

6.0 CONDITIONS OF USE

6.1 Installation must comply with this Research Report, the manufacturer's published installation instructions, and the

applicable Code. In the event of a conflict, this report governs.

6.2 See Section 1.3 for construction type(s) and use classifications.

6.3 Conventional wood railing supports including 4x4 posts, and framing are not within the scope of this report and are subject to evaluation and approval by the building official. Supports must satisfy the design load requirements specified in Chapter 16 of the IBC. Supports and framing must provide suitable material for anchorage of the rail brackets and posts, respectively. Where required by the building official, engineering calculations and details shall be provided.

6.4 Any component or configuration not identified in this report has not been evaluated for performance and/or compliance to the referenced codes. Identification of such components with the CCRR program mark or number is prohibited.

6.5 Only those types of fasteners and fastening methods described in this report have been evaluated for the installation of the *Fairway V100 Series* vinyl railing systems; other methods of attachment are outside the scope of this report.

6.6 Compatibility of fasteners and other installation hardware with the supporting construction including treated wood is not within the scope of this report.

6.7 The *Fairway V100 Series* vinyl railing systems are manufactured under a quality control program with inspections by Intertek Testing Services NA, Inc.

7.0 SUPPORTING EVIDENCE

7.1 Manufacturer's drawings and installation instructions.

7.2 Reports of testing demonstrating compliance with ICC-ES AC174, Acceptance Criteria for Deck Board Span Ratings and Guardrail Systems (Guards and Handrails), revised December 2014.





7.3 Reports of testing and engineering analysis demonstrating compliance with the performance requirements of ASTM D7032-14, Standard Specification for Establishing Performance Ratings for Wood-Plastic Composite and Plastic Lumber Deck Boards, Stair Treads, Guards, and Handrails.

7.4 Documentation of an Intertek approved quality control system for the manufacturing of products recognized in this report.

8.0 IDENTIFICATION

The *Fairway V100 Series* vinyl railing systems are identified with the manufacturer's name, address and telephone number, the product name, the statement "See CCRR-0382 at www.intertek.com/building/ccrr for uses and performance levels.", the phrase "For Use in One- and Two-Family Dwellings Only" for the applicable railing assemblies (See Table 1), the Intertek Mark as shown below, and the Code Compliance Research Report number (CCRR-0382).



9.0 OTHER CODES

9.1 Scope of Evaluation:

Fairway V100 Series vinyl railing systems were evaluated for compliance with the *Florida Building Code -Building* and *Florida Building Code -Residential*.

9.2 Conclusion:

Fairway V100 Series vinyl railing systems, described in Sections 2.0 through 7.0 of this Research Report, comply with the *Florida Building Code – Building*, *Florida Building Code – Residential*, subject to the following conditions:

- Use of *Fairway V100 Series* vinyl railing systems for compliance with the High-Velocity Hurricane Zone provisions of the *Florida Building Code – Building* and *Florida Building Code – Residential* has not been evaluated and is outside the scope of this Research Report.
- Intertek is a Florida State Product Evaluation Entity.

10.0 CODE COMPLIANCE RESEARCH REPORT USE

10.1 Approval of building products and/or materials can only be granted by a building official having legal authority in the specific jurisdiction where approval is sought.

10.2 Code Compliance Research Reports shall not be used in any manner that implies an endorsement of the product by Intertek.

10.3 Reference to the <https://bpdirectory.intertek.com> is recommended to ascertain the current version and status of this report.

This Code Compliance Research Report ("Report") is for the exclusive use of Intertek's Client and is provided pursuant to the agreement between Intertek and its Client. Intertek's responsibility and liability are limited to the terms and conditions of the agreement. Intertek assumes no liability to any party, other than to the Client in accordance with the agreement, for any loss, expense or damage occasioned by the use of this Report. Only the Client is authorized to permit copying or distribution of this Report and then only in its entirety, and the Client shall not use the Report in a misleading manner. Client further agrees and understands that reliance upon the Report is limited to the representations made therein. The Report is not an endorsement or recommendation for use of the subject and/or product described herein. This Report is not the Intertek Listing Report covering the subject product and utilized for Intertek Certification and this Report does not represent authorization for the use of any Intertek certification marks. Any use of the Intertek name or one of its marks for the sale or advertisement of the tested material, product or service must first be approved in writing by Intertek.





TABLE 1 – FAIRWAY V100 SERIES VINYL RAILING SYSTEMS USE GROUP CLASSIFICATIONS

Type	Maximum Railing Dimensions ⁽¹⁾	Top Rail Aluminum Reinforcement	Support	Use Group Classification
Level	96 inch x 42 inch	Aluminum “T” profile with 0.063-inch nominal wall thickness.	Structural wood support ⁽²⁾	IBC / FBC – All Use Groups IRC / FBC-Residential – One and Two-Family Dwellings

⁽¹⁾Level rail lengths are maximum clear length between supports. Railing height is the minimum installed height from walking surface to top of top rail.

⁽²⁾Railing supports are not within the scope of this evaluation.

TABLE 2 – FAIRWAY V100 SERIES FASTENING SCHEDULE

CONNECTION		FASTENER	QUANTITY
Top Rail Bracket	to Post	#8-8 by 1-5/8-inch long, flat head, stainless steel, thread-cutting self-tapping screws	3
	to Rail	#10-16 by 3/4-inch long, pan-head, plated steel, Tek screws	2
Bottom Rail Bracket	to Post	#8-8 by 1-5/8-inch long, flat head, stainless steel, thread-cutting self-tapping screws	3
	to Rail	#10-16 by 3/4-inch long, pan-head, plated steel, Tek screws	2
Baluster to Top/Bottom Rail		Slip fit into routing - No mechanical connection	-
Foot Block to Bottom Rail		#10-16 by 3/4-inch long, pan-head, plated steel, Tek screws	1



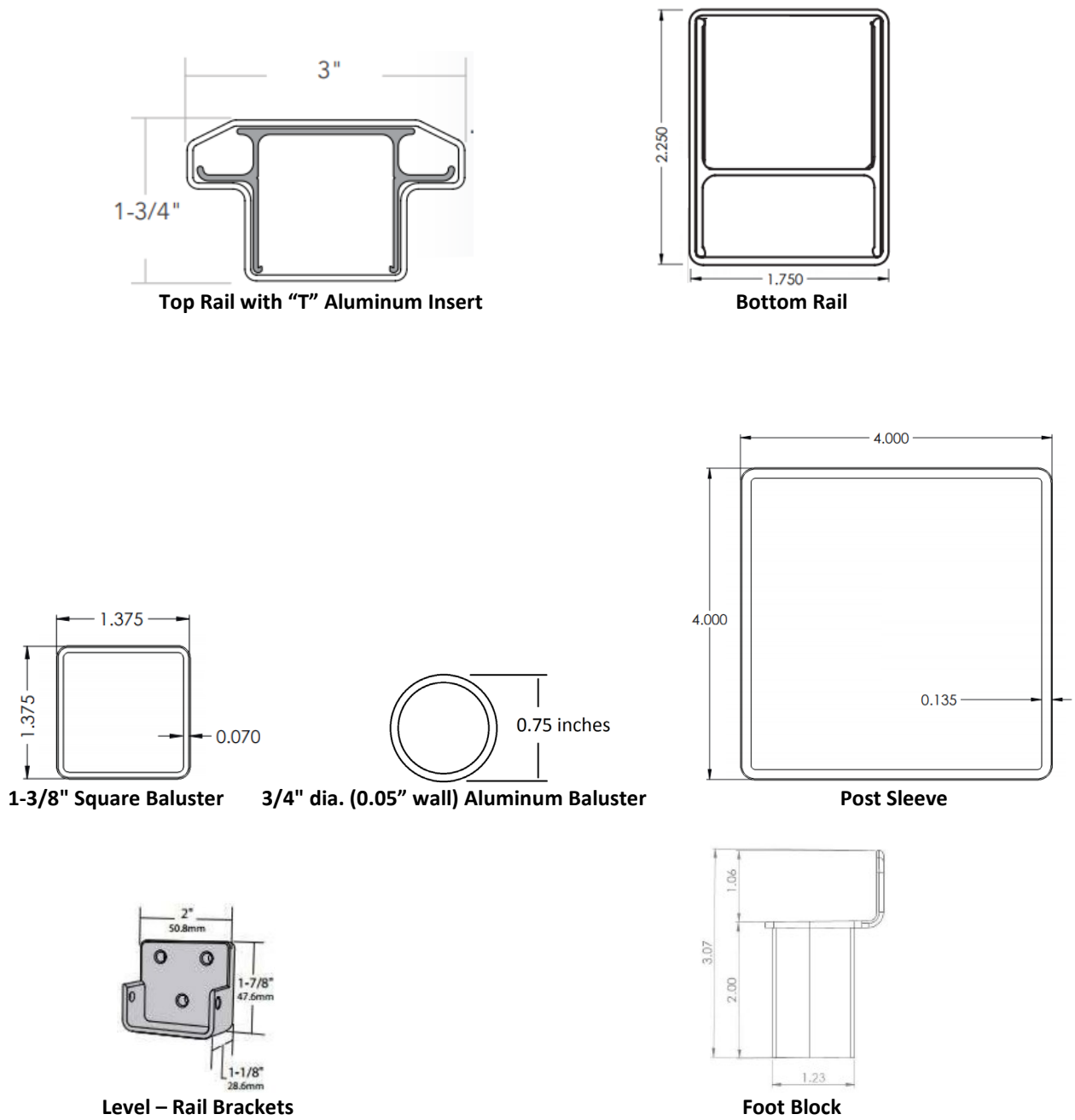

FIGURE 1 – V100 SERIES PVC RAILING SYSTEM COMPONENTS