

Issue Date: 03-12-2010
Revision Date: 08-13-2024
Renewal Date: 08-31-2025

DIVISION: 06 – WOOD, PLASTICS AND COMPOSITES
Section: 06 63 00 – Plastic Railings

REPORT HOLDER:
ENVISION OUTDOOR LIVING PRODUCTS, LLC
53 EBY CHIQUES ROAD
P.O. BOX #37
MOUNT JOY, PA 17552
(800) 598-5245
www.envisionoutdoorliving.com

REPORT SUBJECT:
V200 Vinyl Railing:
V210 Vinyl Railing
V220 Vinyl Railing

1.0 SCOPE OF EVALUATION

1.1 This Research Report addresses compliance with the following Codes:

- 2024, 2021, 2018 *International Building Code*® (IBC)
- 2024, 2021, 2018 *International Residential Code*® (IRC)
- 2023, 2020 *Florida Building Code* (FBC) excluding High Velocity Hurricane Zone (see Section 9.0)

NOTE: This report references the most recent Code sections cited. Section numbers in earlier editions may differ.

1.2 *V200 Vinyl Railing* has been evaluated for the following properties:

- Structural Performance
- Durability
- Surface Burning

1.3 *V200 Vinyl Railing* has been evaluated for the following uses:

- On elevated walking areas in buildings and walkways as required by the codes.
- Guard Assemblies – Railing systems are provided as level guards for level walking areas such as decks, balconies and porches, and sloped guard for open sides of stairways.

- Guard systems recognized in this report may be used in One- and Two-Family Dwellings regulated by the IRC and all construction types regulated by the IBC in accordance with IBC Sections 705.2.2 and 705.2.3.1, Exceptions 2 and 3. Guards less than 42 inches high are limited to use in One- and Two-Family Dwellings (IRC). See Table 1 for additional restrictions based upon Use and Occupancy classification.

2.0 STATEMENT OF COMPLIANCE

V200 Vinyl Railing complies with the Codes listed in Section 1.1, for the properties stated in Section 1.2 and uses stated in Section 1.3, when installed as described in this report, including the Conditions of Use stated in Section 6.0.

3.0 DESCRIPTION

3.1 Level guards with a 36 inch overall installed height are provided in lengths up to 10 feet (120 inches). Guards with a 42 inch overall installed height are provided in lengths up to 8 feet (96 inches). See Table 1 – Maximum Railing System Size and Code Recognition.

3.2 Stair guards are provided in lengths up to 8 feet (96 inches) sloping length with a height up to that corresponding to a 42-inch level rail. See Table 1 – Maximum Railing System Size and Code Recognition.

3.3 Materials and Processes - Railings are an assemblage of extruded and molded components utilizing Poly Vinyl Chloride (PVC) material and aluminum reinforcements. Vinyl components are produced in three colors: White, Almond, and Khaki. All systems consist of the following components:

3.3.1 The top and bottom rails are extruded PVC profiles of various styles.

3.3.2 Balusters are extruded PVC profiles in various dimensions or 3/4" dia. aluminum balusters. Some PVC extrusions are reshaped by a thermoform process to



simulate a turned spindle design. See Table 4 for a list of styles.

3.3.3 An extruded aluminum (6105-T5 or 6005-T5) insert provides reinforcement for the top and bottom rails.

3.3.4 Top and bottom rails are connected to posts with molded plastic brackets (See Figure 7) that are secured to the supports with stainless steel screws.

3.3.5 Supports - Railing systems are attached to conventional wood supports which are outside the scope of this report. A PVC post sleeve that is non-structural is provided as a cladding over conventional 4x4 wood posts.

4.0 PERFORMANCE CHARACTERISTICS

4.1 The railing systems described in this report have demonstrated the capacity to resist the design loadings for Guards specified in Chapter 16 of the IBC when tested in accordance with ICC-ES AC174.

4.2 Structural performance has been demonstrated for a temperature range from -20°F to 125°F.

4.3 Materials used are deemed equivalent to preservative treated or naturally durable wood for resistance to weathering effects, decay, and attack from termites.

4.4 The PVC materials have a flame spread index not exceeding 200 when tested according to ASTM E84.

5.0 INSTALLATION

5.1 General:

V200 Vinyl Railing must be installed in accordance with the manufacturer's published installation instructions, the applicable Code, and this Research Report. A copy of the manufacturer's instructions must be available on the jobsite during installation.

5.2 Application:

5.2.1 Railing assemblies consist of top and bottom rails with pre-routed holes to receive balusters. Aluminum railing

reinforcements are inserted in the rails during assembly as specified for the type and length of railing (see Table 2 and Table 3).

5.2.2 Railings attached to wood supports with molded PVC brackets utilize stainless steel "Hi-Lo" wood screws for anchorage. The wood in the supporting structure shall have a specific gravity of 0.50 or greater (Southern Yellow Pine or better) and a minimum thickness to allow full penetration of the bracket mounting screws. Bracket attachment shall be in accordance with Table 5.

5.2.2.1 Where required by the building official, engineering calculations and details shall be provided. The calculations shall verify that the anchorage complies with the building code for the type and condition of the supporting construction.

5.2.2.2 Compatibility of fasteners and other installation hardware with the supporting construction including treated wood is not within the scope of this report.

6.0 CONDITIONS OF USE

6.1 Installation must comply with this Research Report, the manufacturer's published installation instructions, and the applicable Code. In the event of a conflict, this report governs.

6.2 Conventional wood guard supports are not within the scope of this report and are subject to evaluation and approval by the building official. Supports must satisfy the design load requirements specified in Chapter 16 of the IBC and must provide suitable material for anchorage of the rail brackets. Where required by the building official, engineering calculations and details shall be provided.

6.3 Compatibility of fasteners, post mount brackets, and other metallic components with the supporting structure, including chemically treated wood, is not within the scope of this report.

6.4 The *V200 Vinyl Railing* is manufactured under a quality control program with inspections by Intertek Testing Services NA, Inc.





7.0 SUPPORTING EVIDENCE

7.1 Reports of tests in accordance with the performance requirements of ICC-ES AC174, *Acceptance Criteria for Deck Board Span Ratings and Guardrail Systems (Guards and Handrails)*, January 2012 (editorially revised April 2014), and ASTM D7032-21, *Standard Specification for Establishing Performance Ratings for Wood-Plastic Composite and Plastic Lumber Deck Boards, Stair Treads, Guards, and Handrails*.

7.2 Manufacturer's drawings and installation instructions.

7.3 Documentation of an Intertek approved quality control system for the manufacturing of products recognized in this report.

7.4 Intertek Listing Report ""[Envision Outdoor Living Products, LLC - V200 Vinyl Railing](#)", on the [Intertek Directory of Building Products](#)

8.0 IDENTIFICATION

V200 Vinyl Railing is identified with the manufacturer's name (Envision Outdoor Living Products, LLC), address and telephone number, the product name (V200 Vinyl Railing), where applicable (for rails over 8 ft. long, as shown in Table 1), the label shall include the phrase: "For Use in One- and Two-Family Dwellings Only", the following statement: "See CCRR-0153 at <https://bpdirectory.intertek.com> for uses and performance levels.", the Intertek Control Number, the Intertek Mark as shown below, and the Code Compliance Research Report number (CCRR-0153).



9.0 FLORIDA BUILDING CODE

V200 Vinyl Railing, described in Sections 2.0 through 7.0 of this Research Report, complies with the 2023 *Florida Building Code – Building and Florida Building Code – Residential* subject to the following conditions:

- Use of V200 Vinyl Railing for compliance with the High-Velocity Hurricane Zone provisions of the 2023 *Florida Building Code – Building and Florida Building Code – Residential* has not been evaluated and is outside the scope of this Research Report.

Intertek is a Florida State Product evaluation entity and quality assurance entity pursuant to Florida Statute 553.842 – *Product Evaluation and Approval*.

10.0 CODE COMPLIANCE RESEARCH REPORT USE

10.1 Approval of building products and/or materials can only be granted by a building official having legal authority in the specific jurisdiction where approval is sought.

10.2 Code Compliance Research Reports shall not be used in any manner that implies an endorsement of the product by Intertek.

10.3 Reference to the <https://bpdirectory.intertek.com> is recommended to ascertain the current version and status of this report.





TABLE 1 – MAXIMUM RAILING SYSTEM SIZE AND CODE RECOGNITION

STYLE	CODE RECOGNITION	
	Maximum Railing Size (Length x Height) ¹	
	IBC and FBC	IRC and FBC-Residential
<i>V210 Vinyl Railing</i>	8' x 42" Level 87-1/2" x 42" Stair	10' x 42" Level 87-1/2" x 42" Stair
<i>V220 Vinyl Railing</i>	8' x 42" Level 91-3/4" x 42" Stair	10' x 42" Level 91-3/4" x 42" Stair

¹ Railing lengths are clear length between supports. Railing height is installed height from walking surface to top of top rail. Minimum bottom rail clearance is 2".

TABLE 2 - LEVEL RAILING SYSTEMS DESCRIPTIONS

STYLE	LEVEL RAILING SYSTEM COMPONENTS (See Table 4 for available Balusters)	
	RAILS	BRACKETS
<i>V210 Vinyl Railing</i>	Top: 2x3-1/2" <i>V210 Vinyl Railing</i> with Alum "H" channel Bottom: 2x3-1/2" <i>V210 Vinyl Railing</i> with Alum "H" Channel	Top: OEM Bottom: OEM
<i>V220 Vinyl Railing</i>	Top: <i>V220 Vinyl Railing</i> with Contour Alum insert Bottom: 2x3-1/2" STD Rail with Alum "H" Channel	Top: Two-Piece <i>V220 Vinyl Railing</i> Bottom: OEM

This Code Compliance Research Report ("Report") is for the exclusive use of Intertek's Client and is provided pursuant to the agreement between Intertek and its Client. Intertek's responsibility and liability are limited to the terms and conditions of the agreement. Intertek assumes no liability to any party, other than to the Client in accordance with the agreement, for any loss, expense or damage occasioned by the use of this Report. Only the Client is authorized to permit copying or distribution of this Report and then only in its entirety, and the Client shall not use the Report in a misleading manner. Client further agrees and understands that reliance upon the Report is limited to the representations made therein. The Report is not an endorsement or recommendation for use of the subject and/or product described herein. This Report is not the Intertek Listing Report covering the subject product and utilized for Intertek Certification and this Report does not represent authorization for the use of any Intertek certification marks. Any use of the Intertek name or one of its marks for the sale or advertisement of the tested material, product or service must first be approved in writing by Intertek.





TABLE 3 – STAIR RAILING SYSTEM DESCRIPTIONS

STYLE	STAIR RAILING SYSTEM COMPONENTS (See Table 4 for available balusters)	
	RAILS	BRACKETS
<i>V210 Vinyl Railing</i>	Top: 2x3-1/2" <i>V210 Vinyl Railing</i> with Alum "H" channel Bottom: 2x3-1/2" STD Rail with Alum "H" Channel	Top: OEM Bottom: OEM
<i>V220 Vinyl Railing</i>	Top: <i>V220 Vinyl Railing</i> with <i>Contour</i> Alum insert Bottom: 2x3-1/2" STD Rail with Alum "H" Channel	Top: <i>V220 Vinyl Railing</i> Stair Bracket Bottom: OEM

TABLE 4 - BALUSTERS

BALUSTER STYLE
1-1/4" Square PVC Baluster
1-3/8" Square PVC Baluster
3/4" Dia. (0.05" wall) Aluminum Baluster

TABLE 5 – RAIL BRACKET FASTENING SCHEDULE

RAIL – BRACKET COMBINATION	BRACKET TO POST	RAIL TO BRACKET
2" x 3-1/2" <i>V210 Vinyl Railing</i> with OEM Bracket	(4) #12 x 1-1/4" Stainless Steel Screws	(2) #10 x 1" self-tapping screws
2-1/4" x 3" <i>V220 Vinyl Railing</i> w/ Two-Piece <i>Contour</i> Bracket	(4) #10 x 2" Stainless Steel Screws	(2) #10 x 1" self-tapping screws
2-1/4" x 3" <i>V220 Vinyl Railing</i> w/ Contoured Stair Bracket	(2) #10 x 4" Stainless Steel Screws	(2) #10 x 1" self-tapping screws



Intertek

545 E. Algonquin Road • Arlington Heights • Illinois • 60005
intertek.com/building



PCA-101

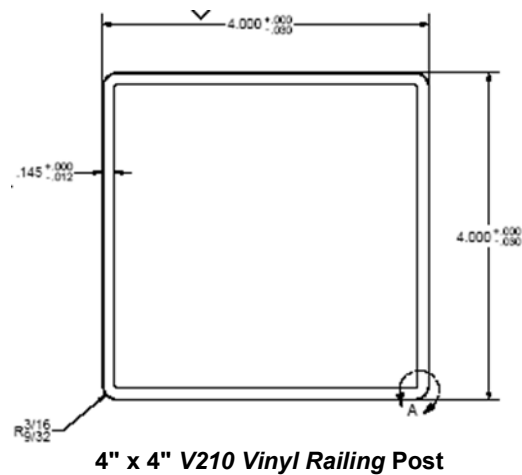
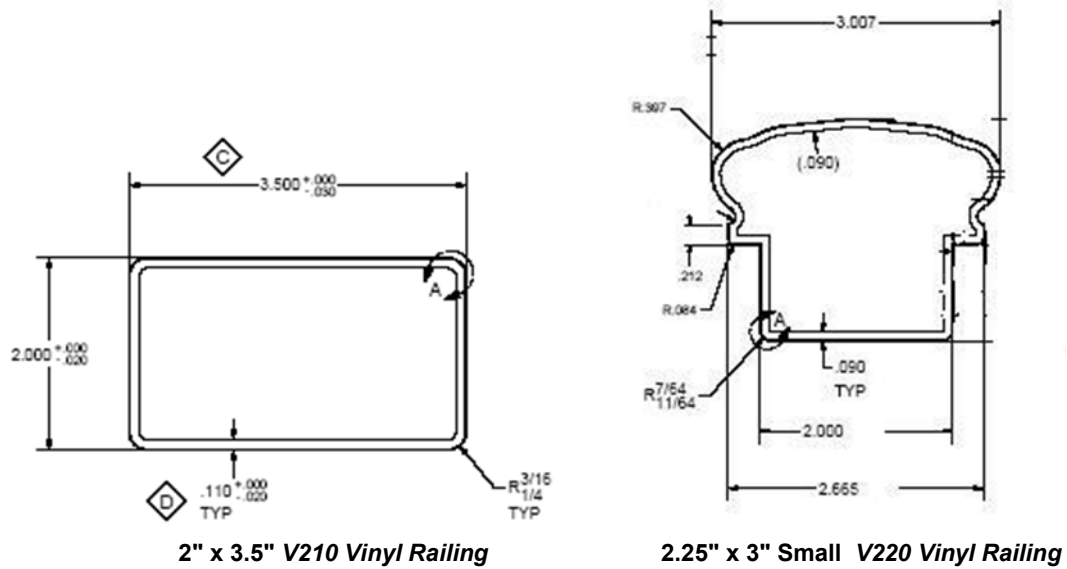

FIGURE 1 – PVC RAIL AND POST PROFILE DRAWINGS

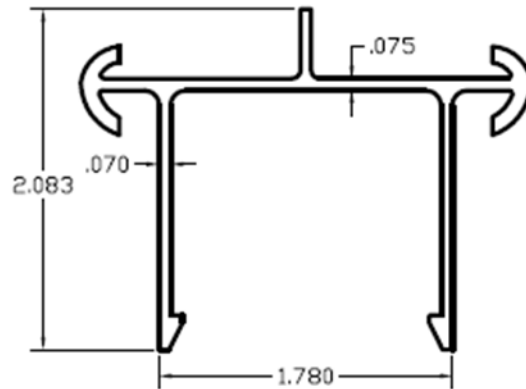

FIGURE 2 – 2.25" X 3.00" V220 VINYL RAILING ALUMINUM INSERT

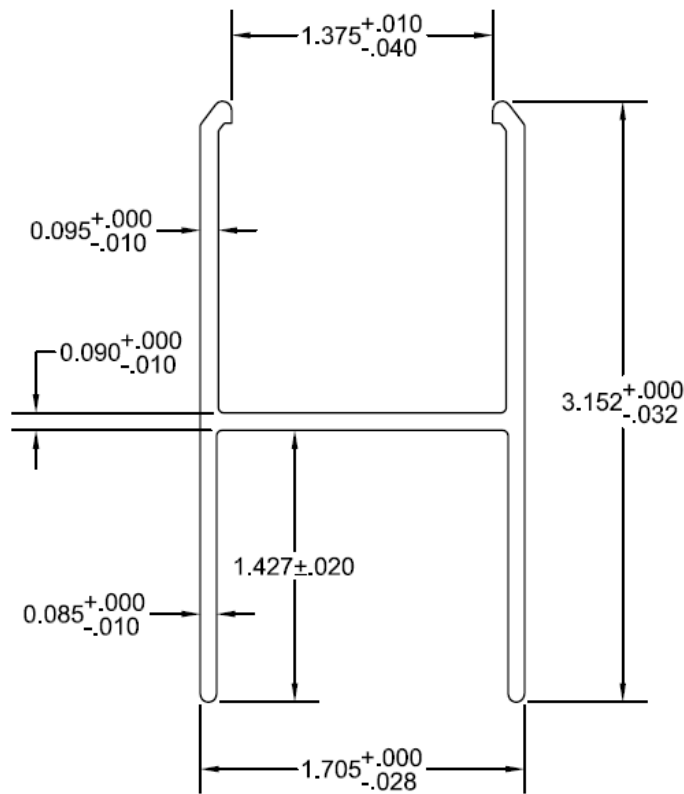
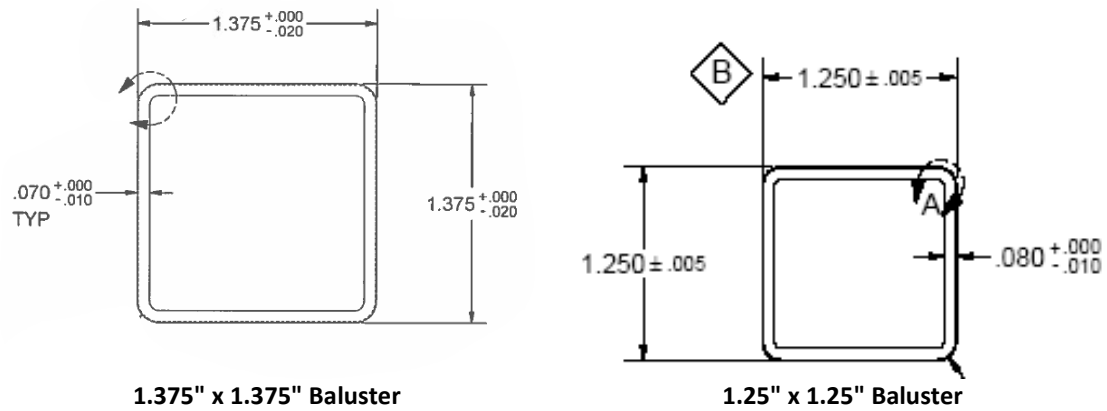

FIGURE 3 - 2.00" X 3.50" V210 VINYL RAILING ALUMINUM H-CHANNEL INSERT



3/4" dia. (0.05" wall) Aluminum Baluster

FIGURE 4 –BALUSTER PROFILES

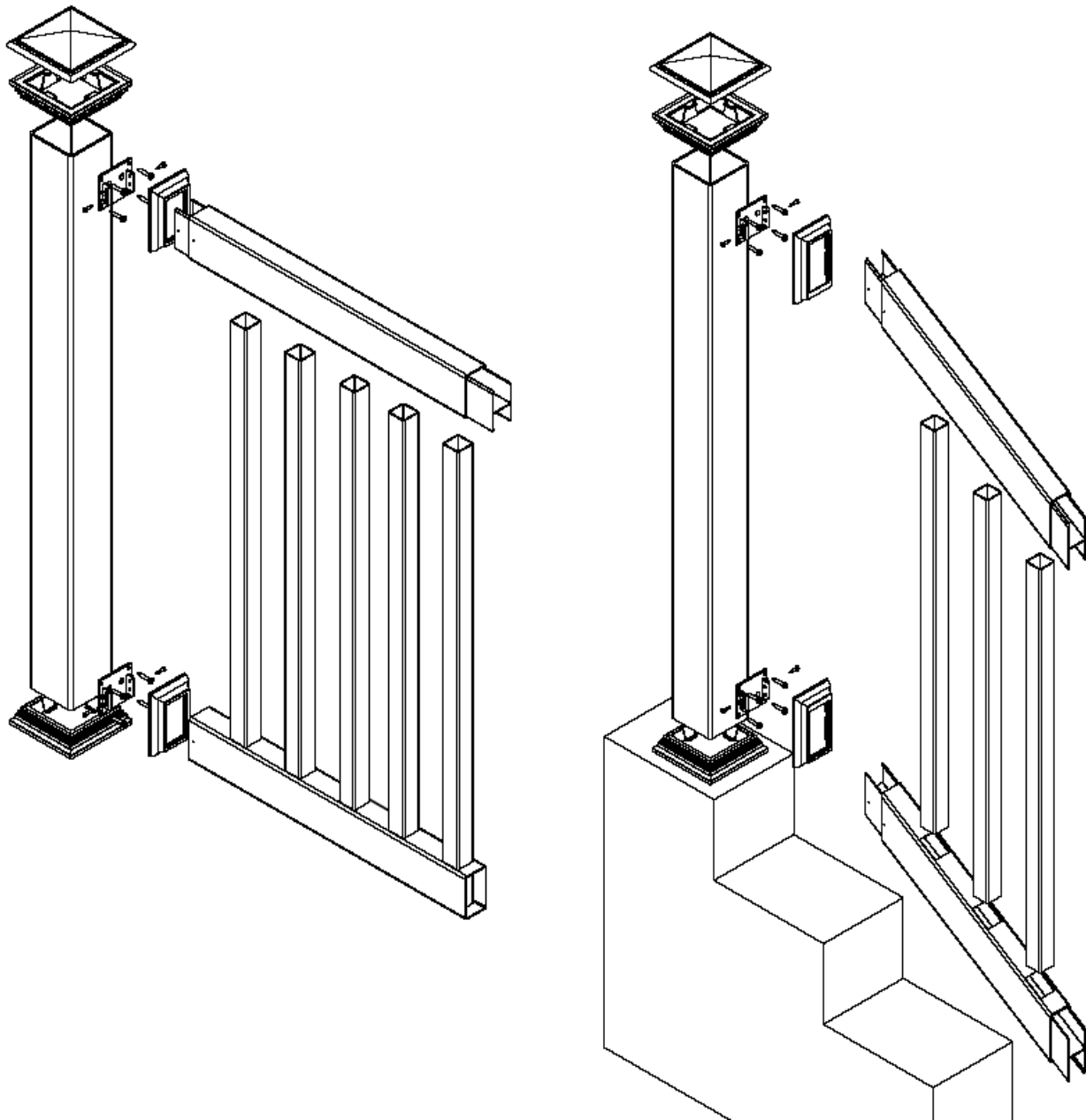

FIGURE 5 – 2 X 3-1/2 V210 VINYL RAILING (LEVEL AND STAIR)
Bottom rail reinforcement not shown for level rail. See Table 2 for requirement.

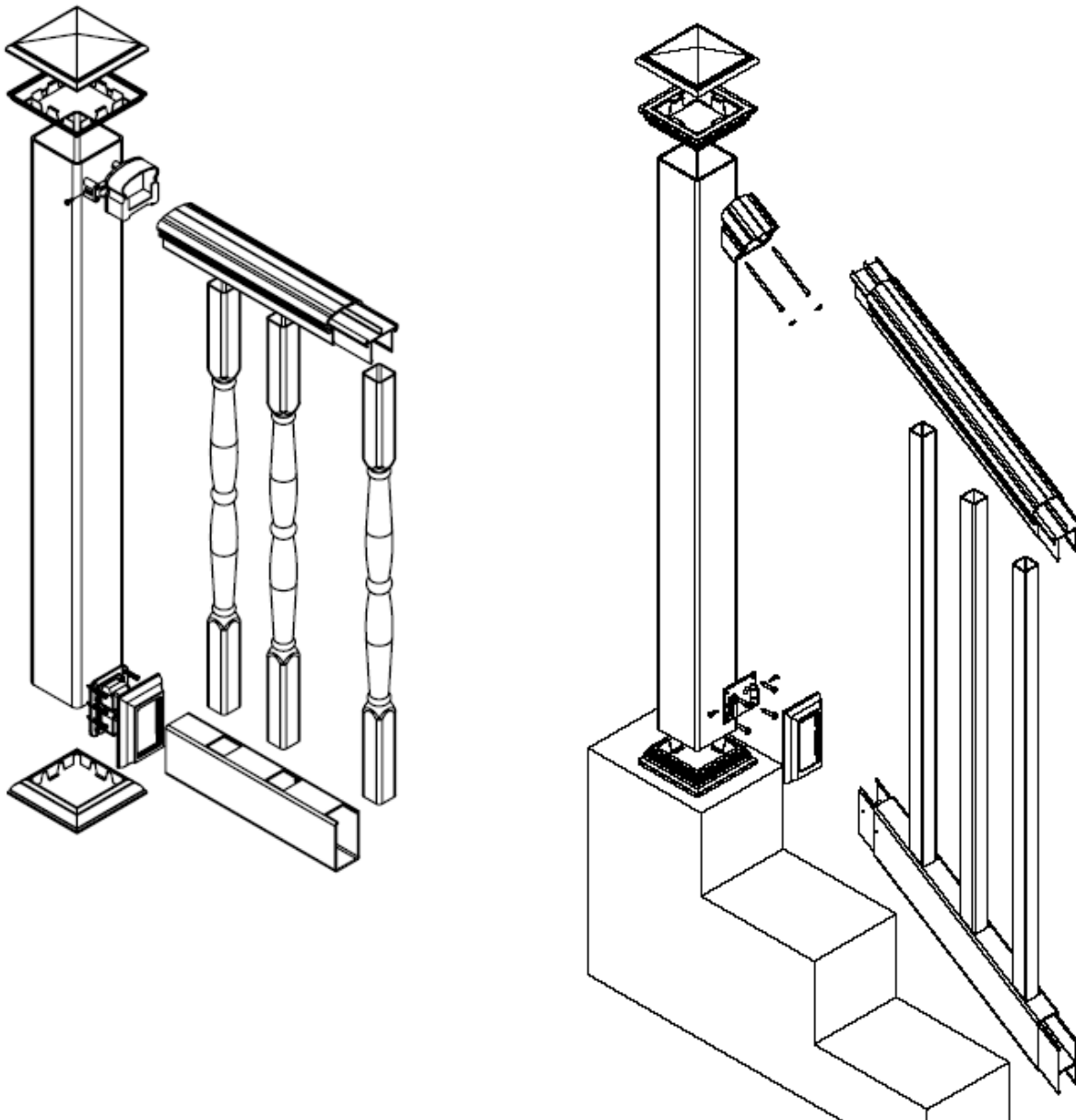

FIGURE 6 - V220 VINYL RAILING (LEVEL AND STAIR)

Bottom rail reinforcement not shown for level rail. See Table 2 for requirement.

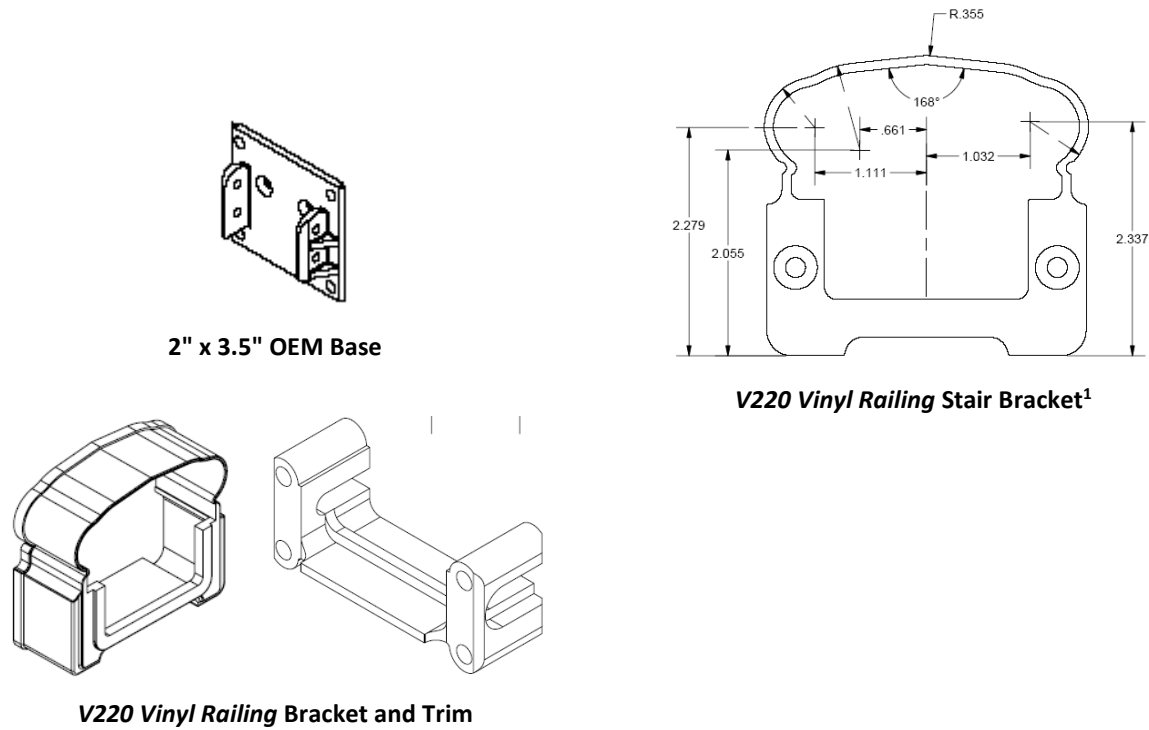

FIGURE 7 - PLASTIC BRACKETS

¹ *Contour* brackets are field cut for a flush fit to the supporting surface with an angle corresponding to the stair slope. The end cut shall be limited to providing the required angle and shall not reduce the overall length of the bracket.